

Type
441, 442
DN 20 - 200
DIN

Vollhub-Feder-Sicherheitsventil bis PN 40
Full Lift Safety Valve up to PN 40 spring loaded
für Dämpfe, Gase und Flüssigkeiten
for steam, gases and liquids

Zusatzausrüstungen

- Edelstahl-Faltenbalg
- Elastomer-Faltenbalg
- Teller mit Weichdichtung
- Lösbare Hubhilfe
- Teller/Sitz gepanzert
- Heizmantel
- Entwässerungsbohrung
- Detailinformationen und weitere Zusatzausrüstungen siehe Teil 13

Accessories

- Stainless steel bellows
- Elastomer bellows
- Disc with soft seal
- Detachable lifting aid
- Disc / Seat stellite
- Heating jacket
- Drain hole

For detailed information and additional accessories refer to section 13

Zulassungen / Approvals

	Dämpfe/Gase D/G Steam/Gases S/G		Flüssigkeiten F Liquids L					
	576		576		576		576	
TÜV (AD-A2, TRD 421) Listennr./Approval number Ausflussziffer/Coefficient of discharge α_d Öffnungscharakteristik/Opening characteristic	576 0,7 Vollhub/Full lift		576 0,45 Normal/Standard		576 0,45 Normal/Standard		576 0,45 Normal/Standard	
ASME/NB (außer/excl. DN 20) Nr./No. Ausflussziffer/Coefficient of discharge K	37044 0,699		37055 0,521		37055 0,521		37055 0,521	
Weitere / Others siehe Seite/refer to page 2/40-41	DGR/PED Kanada	BV KISCO	CBPVI LROS	DIN GOST RINA	DNV TMBEF	GL Tschechien	ISPESL UDT	

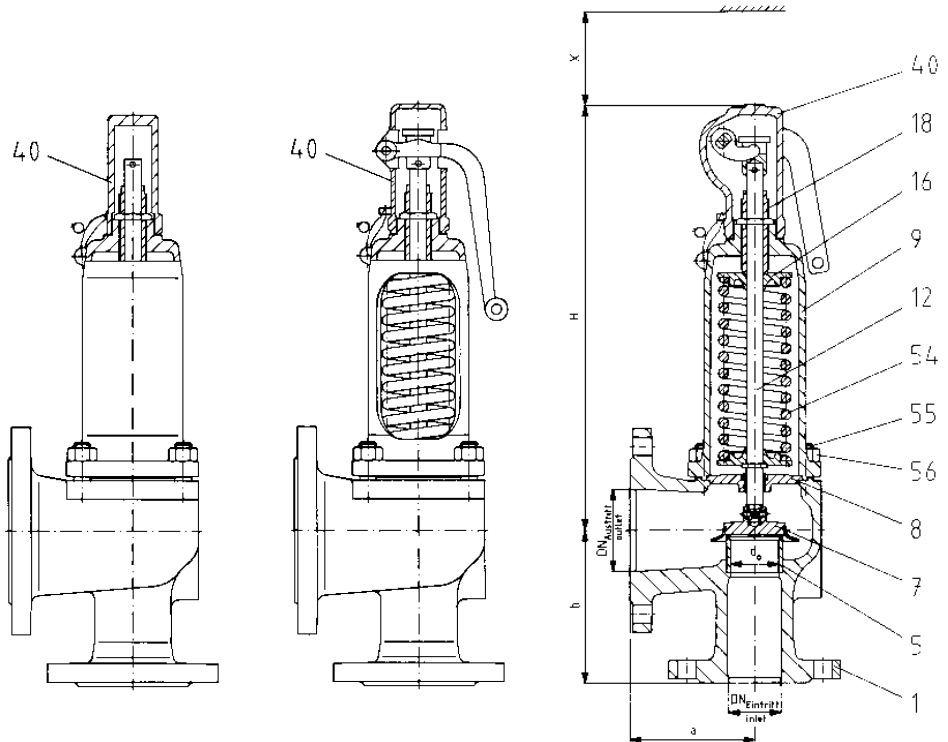

Type 441
mit gasdichter Kappe H2
with gastight cap H2

Type 442
offene Federhaube mit
Anlüftung H3,
Teller anlüftbar
open bonnet
lifting device H3,
disc liftable

Type 441
geschlossene Federhaube mit
Anlüftung H4, gasdicht,
Teller anlüftbar
closed bonnet
lifting device H4, gastight,
disc liftable

Gehäusewerkstoff Body material			DN		Flanschanschlüsse 1) Flange connections 1)		Temperatureinsatzbereich °C 2) Temperature range °F 2) Federhaube				Type	
DIN EN		ASME	von	bis	Eintritt	Austritt	DIN EN		ASME		geschl.	offen
Werkstoffbezeichnung	Werkstoff-Nr.		from	to	Inlet	Outlet	from	to	from	to	closed	open
GG-25	0.6025	-	25	150	16	16	-10/+14	+300/+572	-	-	4411	4421
GGG-40.3	0.7043	SA 395	25	100	40	16	-60/-76	+350/+662	-10/+14	+350/+662	4415	4425
			200	150	16	16						
			200	150	25	10						
GP 240 GH	1.0619	SA 216 WCB	20	150	40	16	-85/-121	+450/+842	-29/-20	+427/+800	4412	4422
			200	150	25	16						
GX5CrNiMo19-11-2	1.4408	SA 351CF8M	25	150	40	16	-270/-454	+400/+752	-268/-450	+300/+572	4414	-

1) Anschlussmaße nach ANSI B16.5 150 lbs. möglich.

2) Zwischen -10 °C und der niedrigsten, angegebenen Anwendungstemperatur ist gemäß AD-Merkblatt W10 zu verfahren.

1) Dimensions acc. to ANSI B16.5 150 lbs. possible.

2) Between -10 °C and lowest temperature indicated "AD-Merkblatt" W10 shall be taken into account.

Änderungen behalten wir uns vor.

Modifications reserved.

Artikelnummern / Article Numbers

Gehäusewerkstoff / Body material				Nennweite / Nominal Diameter												
DIN EN		Werkstoff-Nr. Material No.	ASME	DN	20	25	32	40	50	65	80	100	125	150	200	
Federhaube / Bonnet	geschlossen closed	GG-25	0.6025	-	4411	.437*	.438*	.439*	.440*	.441*	.442*	.443*	.444*	.445*	.446*	-
		GGG-40.3	0.7043	SA 395	4415	-	.738*	.739*	.740*	.741*	.742*	.743*	.744*	.745*	.746*	.747*
		GP 240 GH	1.0619	SA 216 WCB	4412	.450*	.451*	.452*	.453*	.454*	.455*	.456*	.457*	.458*	.459*	.461*
		GX5 CrNiMo 19-11-2	1.4408 ¹⁾	SA 351CF8M	4414	-	.464*	.465*	.466*	.467*	.468*	.469*	.470*	.471*	.472*	-
	offen open	GG-25	0.6025	-	4421	.4375	.4385	.4395	.4405	.4415	.4425	.4435	.4445	.4455	.4465	-
		GGG-40.3	0.7043	SA 395	4425	-	.7385	.7395	.7405	.7415	.7425	.7435	.7445	-	-	.7475
		GP 240 GH	1.0619	SA 216 WCB	4422	.4505	.4515	.4525	.4535	.4545	.4555	.4565	.4575	.4585	.4595	.4615

* Bitte hier gewünschte Ziffer für Kappe oder Anlüftung anfügen:

- 2 = Kappe H 2
- 3 = Anlüftung H 3 (offen)
- 4 = Anlüftung H 4 (gasdicht)

- 1) H3 ist bei diesem Werkstoff nicht lieferbar.
- 2) Artikelnummer auf Anfrage.

Bei Bestellung bitte Artikelnummer, Ansprechdruck und Anschlüsse entsprechend Bestellbeispiel im Teil 1, Ansprechdruck und ggf. Zusatz-ausrüstung (siehe Teil 13) angeben.

* Please add number for the required cap or lifting device:

- 2 = Cap H 2
- 3 = Lifting device H 3 (open)
- 4 = Lifting device H 4 (gastight)

- 1) H3 is not available in this material.
- 2) Article number on request.

In event of order please state article number corresponding to the example for ordering in section 1, set pressure and if necessary, accessories (refer to section 13).

Abmessungen, Druckbereiche, Gewichte / Dimensions, Pressure Ranges, Weights

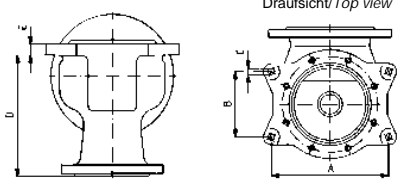
Nennweite, Ventilgröße		Nominal Diameter, Valve size		DN	-	20	20	25	32	40	50	65	80	100	125	150	200		
Nennweite, Austritt		Nominal Diameter, Outlet		DN	-	32	40	40	50	65	80	100	125	150	200	250	300		
Druckstufe Eintritt	GG	Pressure rating Inlet	CI	PN	-	16	-	16								-			
	GGG		NCI	PN	-	-	-	40								16	16	25	
	GS, GX		CS, SS	PN	-	-	40										25		
Druckstufe Austritt	GG	Pressure rating Outlet	CI	PN	-	16	-	16								-			
	GGG		NCI	PN	-	-	-	16								10			
	GS		CS	PN	-	-	16												
Max. Ansprechdruck	GG	Max. Set pressure	CI	p	bar/bar g	16	-	16								-			
	GGG		NCI	p	bar/bar g	-	-	40				32	40	16	16	20			
	GS		CS	p	bar/bar g	-	40				32	40	28	17	20				
	GX ¹⁾		SS ¹⁾	p	bar/bar g	-	-	40		33	28	13,6	15	15	7	-			
Engster Strömungsquerschnitt		Flow area		A ₀	mm ²	254	254	416	661	1075	1662	2827	4301	6648	7543	12272	21382		
Engster Strömungsdurchmesser		Flow diameter		d ₀	mm	18	18	23	29	37	46	60	74	92	98	125	165		
Schenkellänge		Centre to face dim.		a	mm	95	95	100	110	115	120	140	160	180	200	225	300		
				b	mm	85	85	105	115	140	150	170	195	220	250	285	290		
Bauhöhe	H2	GG GGG GS	H2	CI	H	mm	-	217	232	315	356	403	481	558	615	615	728	1090	
	H3		NCI	H	mm	215	218	233	325	366	413	526	603	660	660	735	1090		
	H4		CS	H	mm	-	219	234	331	372	419	529	606	663	663	735	1090		
	H2	GX	H2	SS	H	mm	-	-	232	315	356	403	481	558	615	615	728		
	H4		H4	H	mm	-	-	234	322	363	410	529	606	663	663	735			
mit Faltenbalg zus.		with bellows add.		H	mm	-	33	39	42	38	46	70	59	56	56	58			
Deckenfreiheit		Height clearance		x	mm	150	150	150	200	250	300	350	400	450	450	450	700		
Gewicht		Weight		-	kg	9	9	9	12	16	22	32	56	75	85	131	285		
Spannpratzen (Nur auf Anforderung gebohrt)		Brackets (Drilled only on request)		A	mm											277	277	320	490
				B	mm											160	160	185	150 ²⁾
				C	mm											∅18	∅18	∅18	∅18
				D	mm											293	318	392	489 ³⁾
				E	mm											21	21	28	25 ⁴⁾

1) Höhere Ansprechdrücke durch Einsatz von Sonderfedern möglich. / Higher set pressures are possible by fitting special springs.

3) GGG/NCI: 290 mm

4) GGG/NCI: 16 mm

2) GS/CS: 100 mm

Werkstoffe / Materials

Pos. Item	Bauteile	Parts	4411/4421	4415/4425	4412/4422	4414	
			GG CI	GGG NCI	GS CS	Korrosionsfest, kaltzäh corrosion resistant, cryogenic	
1	Gehäuse	Body	GG-25 0.6025	GGG-40.3 0.7043	GP 240 GH 1.0619	GX5 Cr Ni Mo 19-11-2 1.4408	
5	Sitz	Seat	X2 Cr Ni Mo 17-12-2				1.4404
7	Teller	Disc	X 39 Cr Mo 17-1 1.4122			X 2 Cr Ni Mo 17-12-2 1.4404	
8	Führungsscheibe	Guide	X 14 Cr Mo S 17/C35/GGG-40 1.4104/1.0501/0.7040			X 2 Cr Ni Mo 17-12-2 1.4404	
	mit Buchse	with bush	X 14 Cr Mo S 17 tenifer 1.4104 tenifer				
9	Federhaube	Bonnet	GGG-40 (GGG-40.3/GP 240 GH) 0.7040 (0.7043/1.0619)			GX5 Cr Ni Mo 19-11-2 1.4408	
						X 2 Cr Ni Mo 17-12-2 1.4404	
						X 6 Cr Ni Mo Ti 17-12-2 1.4571	
12	Spindel	Spindle	X 20 Cr 13 1.4021			X 2 Cr Ni Mo 17-12-2 1.4404	
16	Federteller	Spring plate	11 S Mn Pb 30/X 2 Cr Ni Mo 17-12-2 1.0718/1.4404			X 2 Cr Ni Mo 17-12-2 1.4404	
18	Druckschraube mit Buchse	Adjusting screw with bush	X 2 Cr Ni Mo 17-12-2/X 14 Cr Mo S 17 1.4404/1.4104			X 2 Cr Ni Mo 17-12-2 1.4404	
			PTFE			PTFE	PTFE
54	Feder	Spring	Federstahldraht C/Spring steel wire C			X 10 Cr Ni 18 8 1.4310	
			t < 200 °C	54 Si Cr 6/51 Cr V 4/X 10 Cr Ni 18 8 1.1200/1.7102/1.8159/1.4310			
			t > 200 °C			54 Cr Si 6/51 Cr V 4/X 10 Cr Ni 18 8 1.7102/1.8159/1.4310	
40	Kappe H 2	Cap H 2	11 S Mn Pb 30/GGG40.3 1.0718/0.7043			X 2 Cr Ni Mo 17-12-2 1.4404	
	Anlüftung H 3	Lifting device H 3	GGG-40 0.7040				
	Anlüftung H 4	Lifting device H 4	GGG-40 0.7040			GX5 Cr Ni Mo 19-11-2 1.4408	
55/ 56	Stiftschraube Mutter	Bolt nut	t < 400 °C			A 4-70/A 4 1.4401/1.4401	
			t > 400 °C			A 4-70/A 4 1.4401/1.4401	

Zuerkannte Ausflussziffer α_d / Coefficient of Discharge α_d

Diagramm 1

$$\alpha_d = f(h/d_o)$$

Diagramm 2

$$\alpha_d = f(p_{a0}/p_o)$$

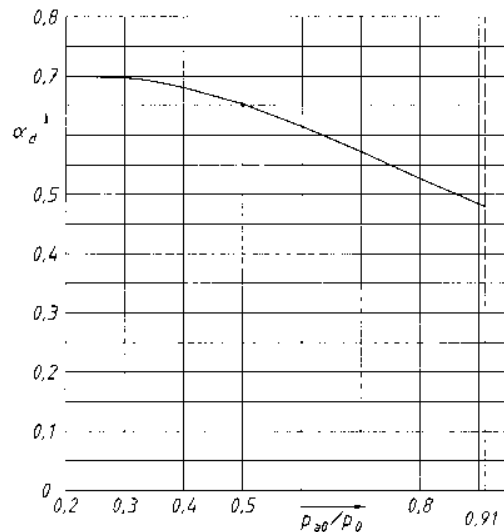
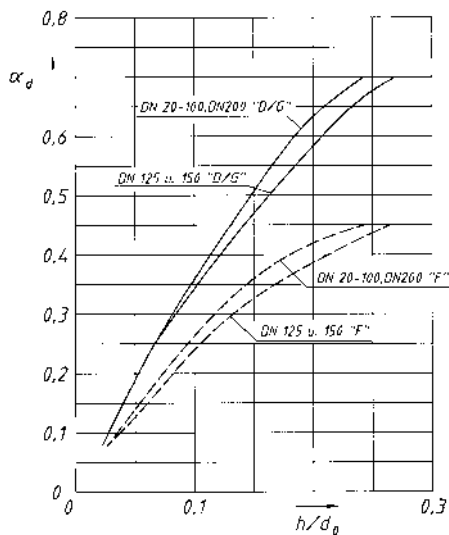

h = Hub (mm)
 d_o = engster Strömungsdurchmesser (mm)
 p_{a0} = Gegendruck, bar (abs.)
 p_o = Ansprechdruck, bar (abs.)

h = Lift (mm)
 d_o = Flow diameter (mm)
 p_{a0} = Back pressure, bar (abs.)
 p_o = Set pressure, bar (abs.)