

# MANUAL TYPE STAINLESS KNIFE GATE VALVE

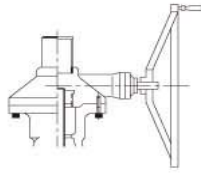

Available With Gear Operator

MODEL- **M** -02

CONNECTION RATING:  
JIS 5K JIS 10K JIS7.5K  
ANSI 150#  
DIN PN10 PN16

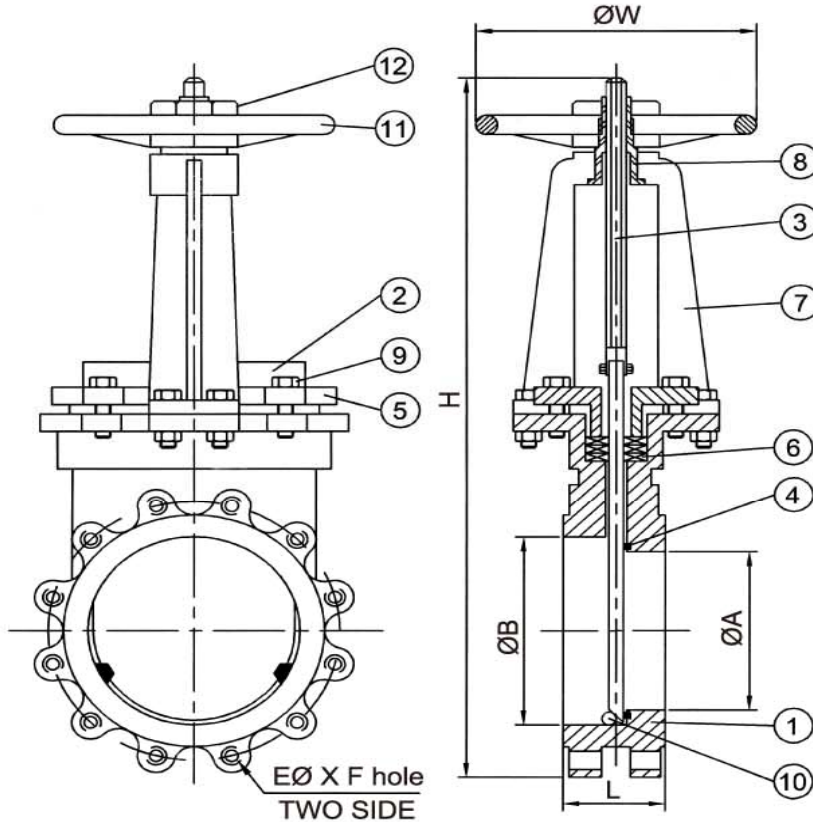

MSS-SP81 TEST STANDARD:  
BODY TEST: 11kg/cm<sup>2</sup> (WATER)  
SEAT TEST: 2.8kg/cm<sup>2</sup> (WATER)  
LEAKAGE: 4 cc/per in.min.

DIMENSION TABLE : MM

SIZE	L	ØA	ØB	W	H
2"	48	42	64	190	420
2-1/2"	51	57	80	190	430
3"	51	72	95	190	430
4"	51	95	120	220	520
5"	57	125	148	290	600
6"	57	150	175	290	660
8"	70	195	222	350	810
10"	70	250	275	350	990
12"	76	300	325	400	1150
14"	76	350	375	400	1230
16"	89	400	430	500	1420
18"	89	435	475	500	1600
20"	114	480	515	500	1700
24"	114	580	620	500	1970

MATERIAL:

	BODY	PLATE	SEAT	GLAND PACKING
MATERIAL	CF8	SUS304	TEFLON	NON-ASB+PTFE
	CF8M	SUS316	METAL	ASB
	CF3M	SUS304L	VITON	ASB+PTFE
		SUS316L	EPDM	TEFLON NON ASBESTOS

TEMPERATURE:

MATERIAL	TEM. RANGE
ASBESTOS+PTFE	-50° ~ 550°C
SILICON	-20° ~ 150°C
VITON	-20° ~ 250°C
TEFLON	-30° ~ 150°C
NON ASBESTOS	-50° ~ 550°C

12	NUT	CAST IRON
11	HAND WHEEL	CAST IRON
10	PAWLS	SUS304
9	BOLT NUT	SUS304
8	YOKE SLEEVE	CAST BRONZE. FCD
7	YOKE	DUCTILE IRON
6	GLAND PACKING	ASB NON-ASB
5	GLAND	SUS304
4	SEAT	TEFLON
3	STEM	SUS410.304.316.316L
2	PLATE	SUS304.316.316L
1	BODY	CF8.CF8M.CF3M
NO.	SUBJECT	MATERIAL

( FOR REFERENCE ONLY. )

( FOR REFERENCE ONLY. )