



Model : M-25

**CAST STAINLESS STEEL LEFT TYPE CHECK VALVE CALSS150LB/10K**

MODEL- -25

BOLTED COVER  
 SWING TYPE  
 FOR HORIZONTAL LINES  
 RENEWABLE SEAT RING  
 FLANGED ENDS  
 BUTTWELDING ENDS

APPLICABLE STANDARDS :  
 SHELL WALL THICKNESS ANSI B16.34  
 FACE TO FACE ANSI B16.10/JISB2002  
 END FLANGES ANSI B16.5/JISB2210

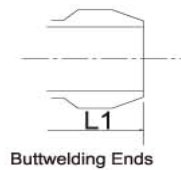
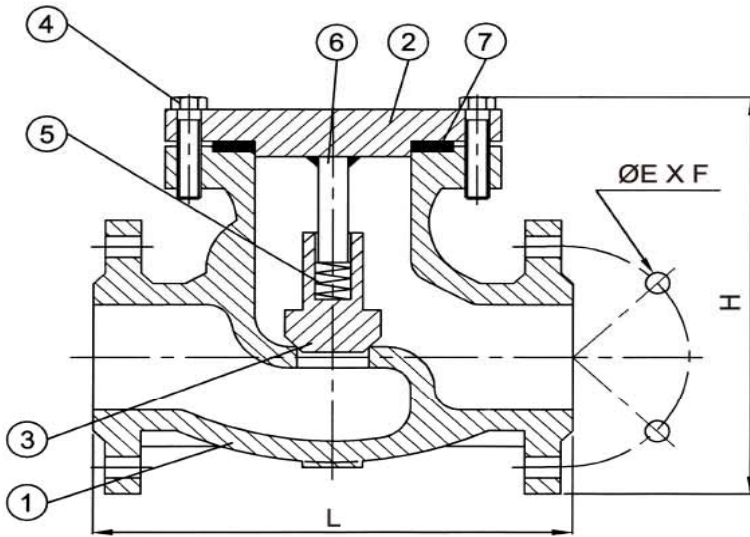

**TEST PRESSURE TO API 598**

|                   | ANSI 150LB                       | JIS 10k               |
|-------------------|----------------------------------|-----------------------|
| SHELL TEST(WATER) | 450 PSI (32 kg/cm <sup>2</sup> ) | 20 kg/cm <sup>2</sup> |
| SEAT TEST(WATER)  | 314 PSI (22 kg/cm <sup>2</sup> ) | 15 kg/cm <sup>2</sup> |
| SEAT TEST(AIR)    | 80 PSI (6 kg/cm <sup>2</sup> )   | 6 kg/cm <sup>2</sup>  |

**PARTS AND MATERIAL(ASTM)**

|          |         |                        |       |       |      |
|----------|---------|------------------------|-------|-------|------|
| 7        | GASKET  | V#1500/GRAPHITE / PTFE |       |       |      |
| 6        | STEM    | A276-304 / 316 / 316L  |       |       |      |
| 5        | SPRING  | SUS304 / SUS316        |       |       |      |
| 4        | BOLT    | A193-B8                |       |       |      |
| 3        | DISC    | SUS304                 | CF8   | CF8M  | CF8M |
| 2        | COVER   | WCB                    | CF8   | CF8M  | CF3M |
| 1        | BODY    | WCB                    | CF8   | CF8M  | CF3M |
| NO.      | SUBJECT | WCB                    | 304SS | 316SS | 316L |
| MATERIAL |         |                        |       |       |      |

**DIMENSION TABLE:**

| SIZE | IN | 1/2 | 3/4 | 1   | 1-1/2 | 2   | 2-1/2 | 3   | 4   | 5   | 6   | 8   | 10  | 12  | 14  | 16  |
|------|----|-----|-----|-----|-------|-----|-------|-----|-----|-----|-----|-----|-----|-----|-----|-----|
|      | MM | 15  | 20  | 25  | 40    | 50  | 65    | 80  | 100 | 125 | 150 | 200 | 250 | 300 | 350 | 400 |
| L    |    | 108 | 117 | 127 | 165   | 203 | 216   | 241 | 292 | 356 | 406 | 495 | 622 | 699 | 787 | 864 |
| H    |    | 114 | 119 | 129 | 158   | 186 | 209   | 215 | 274 | 297 | 324 | 421 | 543 | 617 | 661 | 708 |