

Forged Steel CHECK VALVE Class 800

Piston, Ball or Spring Type

Bolted Bonnet

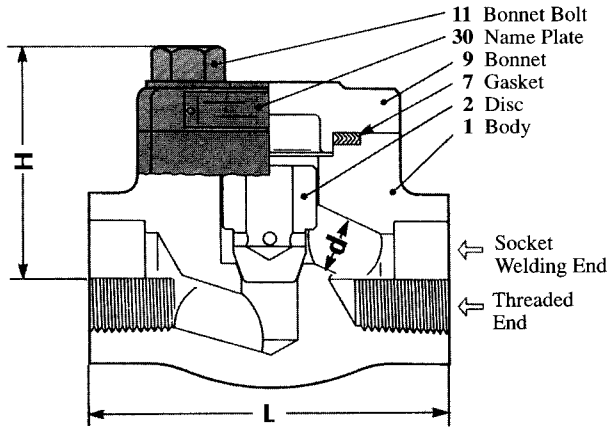

Piston Check

SHORITSU Type No.

0 43Reduced Port

F 43Full Port

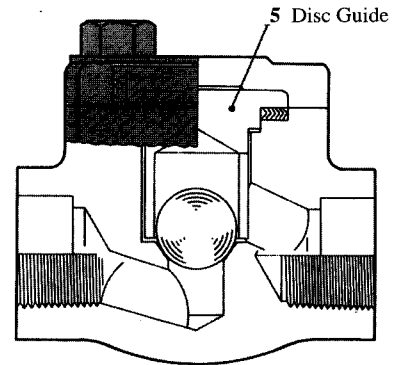

Ball Check

SHORITSU Type No.

0 45Reduced Port

F 45Full Port

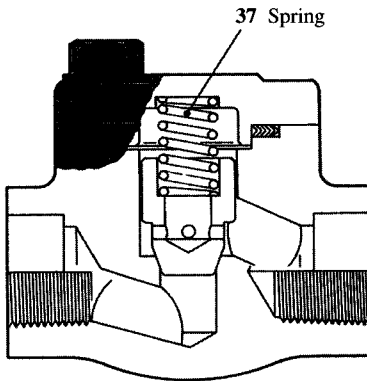

Spring Check

SHORITSU Type No.

0 47Reduced Port

F 47Full Port

For further detailed information:
See Page 6 for Dimensions of End Connections,
Page 7 for Gasket,
Page 8 for Materials.

DIMENSIONS (mm)

		Valve Size, inch	1/4	3/8	1/2	3/4	1	1-1/4	1-1/2	2
Reduced Port	d	Port Dia.	6.5	6.5	10	13	17.5	23	31	37
	L	End to End	79	79	79	92	111	152	152	172
	H	Center to Top	61	61	61	61	78	103	103	118
		Weight, kg	1.3	1.3	1.3	1.6	3.1	6.4	6.4	8.9
Full Port	d	Port Dia.	6.5	10	13	17.5	23	31	37	
	L	End to End	79	79	92	111	152	152	172	
	H	Center to Top	61	61	61	78	103	103	118	
		Weight, kg	1.3	1.3	1.6	3.1	6.4	6.4	8.9	

Dimensions Of End Connections

Flanged End (ANSI, Raised Face)

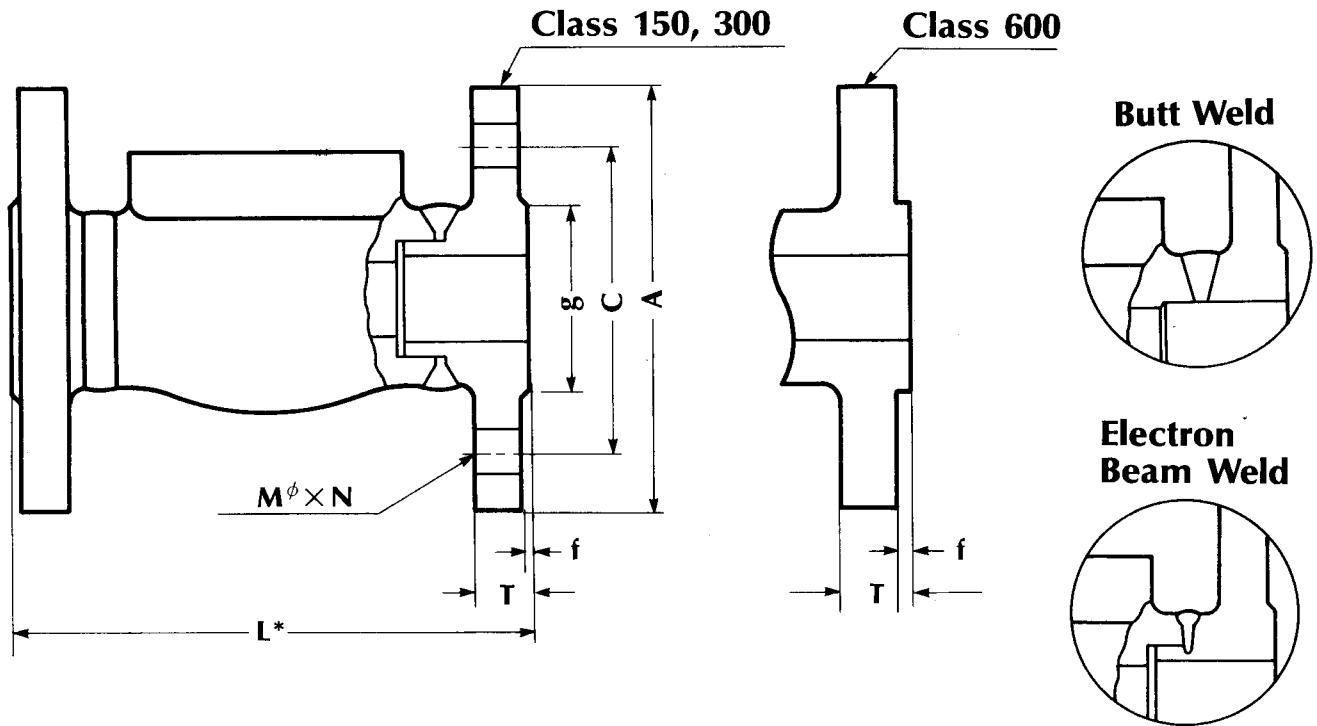

DIMENSIONS (mm)

Class	Size, inch	GATE		GLOBE CHECK		L	A	C	g	T	f	Mφ x N
		L										
150	1/2	140	152	89	60.3	34.9	11.5	1.6	16 x 4			
	3/4	152	178	98	69.9	42.9	13.0	1.6	16 x 4			
	1	165	203	108	79.4	50.8	14.5	1.6	16 x 4			
	1-1/4	178	216	117	88.9	63.5	16.0	1.6	16 x 4			
	1-1/2	190	229	127	98.4	73.0	17.5	1.6	16 x 4			
	2	216	267	152	120.6	92.1	19.5	1.6	20 x 4			
300	1/2	140	152	95	66.7	34.9	14.5	1.6	16 x 4			
	3/4	152	178	117	82.5	42.9	16.0	1.6	20 x 4			
	1	165	203	124	88.9	50.8	17.5	1.6	20 x 4			
	1-1/4	178	216	133	98.4	63.5	19.5	1.6	20 x 4			
	1-1/2	190	229	156	114.3	73.0	21.0	1.6	23 x 4			
	2	216	267	165	127.0	92.1	22.5	1.6	20 x 8			
600	1/2	165		95	66.7	34.9	14.5	6.4	16 x 4			
	3/4	190		117	82.5	42.9	16.0	6.4	20 x 4			
	1	216		124	88.9	50.8	17.5	6.4	20 x 4			
	1-1/4	229		133	98.4	63.5	21.0	6.4	20 x 4			
	1-1/2	241		156	114.3	73.0	22.5	6.4	23 x 4			
	2	292		165	127.0	92.1	25.5	6.4	20 x 8			

* Class 150 Face to Face Dimension "L" is same as Class 300.

クラス 150 面間寸法は、クラス 300 面間寸法を採用しています。

Forge Steel Check Valve Class 800

BODY MARKING

**Class 800
FORGED STEEL**

DRAWING No.	4 32 ACI - 1B
FIG. No.	432A
USER JOB No.	
USER REO No.	

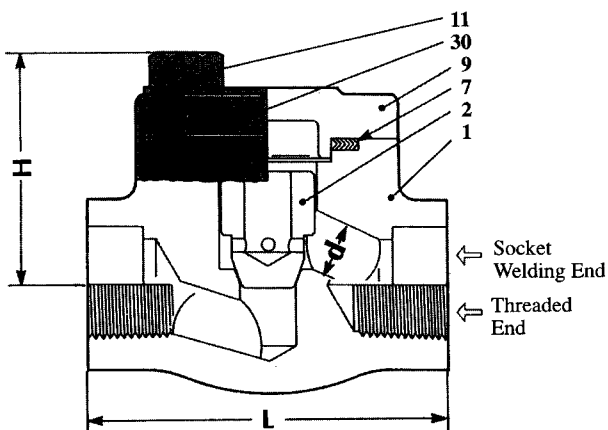

DIMENSIONS (mm)

size	1/4B	3/8B	1/2B	3/4B	1B	1 1/4B	1 1/2B	2B
d	6.5	6.5	10	13	17.5	23	31	37
L	79	79	79	92	111	152	152	172
d1	NPT 1/4	NPT 3/8	NPT 1/2	NPT 3/4	NPT 1	NPT 1 1/4	NPT 1 1/2	NPT 2
S	10.2	10.4	13.6	13.9	17.3	18.0	18.4	19.2
H	61	61	61	61	78	103	103	118



SHORITSU SEISAKUSHO CO., LTD.

11	BONNET BOLT	A193 B7		4	
9	BONNET	A105	S28C	1	
7	GASKET	ASBESTOS SPIRAL WOUND		1	
3	DISC	A276 420	SUS420J2	1	
1	BODY	A105	S28C	1	STELLITE WELD
NO:	NAME OF PARTS	ASTM	JIS	PIE -CE	REMA -RK
TITLE		API 602 DROP FORGED STEEL LIFT CHECK VALVE THREADED-END			
BODY T.P.		WATER $\frac{210 \text{ Kgt/cm}^2\text{G}}{(\text{MP}_g)}$		WATER SEAT T.P. $\frac{153 \text{ Kgt/cm}^2\text{G}}{(\text{MP}_g)}$	
REMARK SEAT T.P. AIR 6 Kgt/cm ² G					
				89,1	
RECOG.	CHECK	DRAWING		DATE	