

Diaphragm Pressure Gauges Process Industry Series Model 432.50/433.50, without/with Liquid Filling

WIKA Data Sheet PM 04.03

Applications

- For measuring points with increased overload
- With liquid filled case for applications with high dynamic pressure pulsations or vibrations
- Suitable for all gaseous and liquid, high-viscosity or solids entrained media, even in aggressive environment
- Process industries: chemical/petro-chemical, power stations, mining, on- and offshore, environmental technology, mechanical engineering and plant construction

Special Features

- Wide selection of special materials
- Compatible with alarm contacts and transmitters
- All stainless steel construction
- Scale ranges from 0 ... 16 mbar



Diaphragm Pressure Gauge Model 432.50

Description

Design

EN 837-3

Nominal size

100 and 160 mm

Accuracy class

1.6

Scale ranges

0 ... 16 mbar to 0 ... 250 mbar (flange Ø 160 mm)

0 ... 400 mbar to 0 ... 40 bar (flange Ø 100 mm)

or other equivalent units of pressure or vacuum

Working pressure

Steady: full scale value

Fluctuating: 0.9 x full scale value

Overpressure safety

5 x full scale value, 40 bar maximum

Operating temperature

Ambient: -20 ... +60 °C

Medium: +100 °C maximum

Temperature effect

When temperature of the pressure element deviates from reference temperature (+20 °C):

max. ±0.8 %/10 K of true scale value

Ingress protection

IP 54 per EN 60 529 / IEC 529

(with liquid filling IP 65)

Standard features

Pressure connection and lower diaphragm housing

Material: stainless steel 316L
Lower mount (LM) G ½ B (male), 22 mm flats

Pressure element

≤0.25 bar: stainless steel 316L
> 0.25 bar: Duratherm (NiCrCo-alloy)

Diaphragm sealing ring

FPM/FKM

Movement

Material: stainless steel

Dial

White aluminium with black lettering

Pointer

Black aluminium pointer

Case and upper diaphragm housing

Stainless steel case with pressure vent in case back

Window

Laminated safety glass

Bezel ring

Cam ring (bayonet type), stainless steel

Liquid filling (for model 433.50)

Glycerine 86.5 %

Optional extras

- Other pressure connection
- Solid front (model 43X.30)
- 10 x overpressure safe, maximum 40 bar
- Vacuum safe up to -1 bar
- Medium temperature +200 °C maximum

Further optional extras

- Accuracy class higher, class 1.0 and 0.6
- Pressure connection with DIN or ASME flange DN 15 to DN 80 (preferably DN 25, DN 50 or DN 1", DN 2" see data sheet IN 00.10)
- Wetted parts lined or coated with special materials such as: PTFE (Teflon) foil (model 45X.50), Hastelloy B2, Hastelloy C4, Monel, Nickel, Tantalum, Titanium, Silver
- Alarm contacts (see data sheet AC 08.01), liquid filled: insulating oil
- Transmitters (see data sheet AE 08.02)

Instruments with special approvals: 1)

- DVGW declaration for the use in gas supply systems
- DIN/DVGW registration: pressure switch acc. to EN 1854
- Pressure switch acc. to VdTÜV codes of practice 100/1
- Conformity certificate for intrinsically safe electrical equipment (mining)
- Gost-standard approval (Russia)
- Design approval for connection to hazardous zone 0

1) specification on inquiry

Dimensions in mm

Standard version

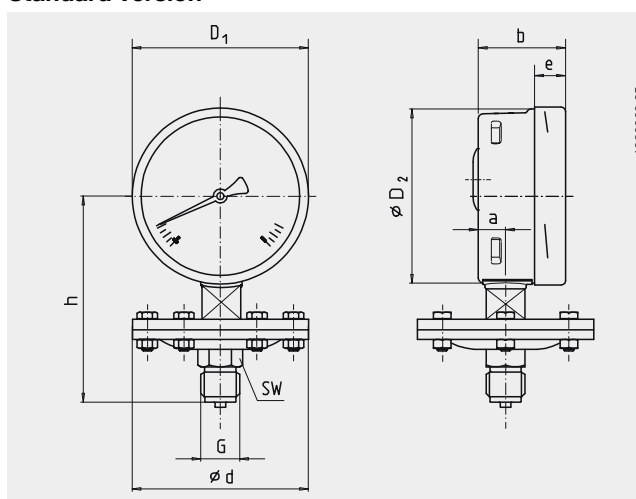

NS	Pressure range in bar	Dimensions in mm			D ₁	D ₂	e	G	h ± 2	SW	Weight in kg
		d	a	b							
100	≤0.25	160	15.5	49.5	101	99	17.5	G ½ B	119	22	2.50
160	≤0.25	160	15.5	49.5	161	159	17.5	G ½ B	149	22	2.90
100	> 0.25	100	15.5	49.5	101	99	17.5	G ½ B	117	22	1.30
160	> 0.25	100	15.5	49.5	161	159	17.5	G ½ B	147	22	1.70

Standard pressure entry with parallel thread and sealing to EN 837-3 / 7.3

Ordering information

Pressure gauge model / Nominal size / Scale range / Size and location of connection / Optional extras required

Modifications may take place and materials specified may be replaced by others without prior notice.
Specifications and dimensions given in this leaflet represent the state of engineering at the time of printing.

